



APERTURA MANUALE MANUAL OPENING



MECCANISMO VERT-MOVE / VERT-MOVE MECHANISM

BARRA DI COLLEGAMENTO 15x15 / CONNECTION BAR 15x15

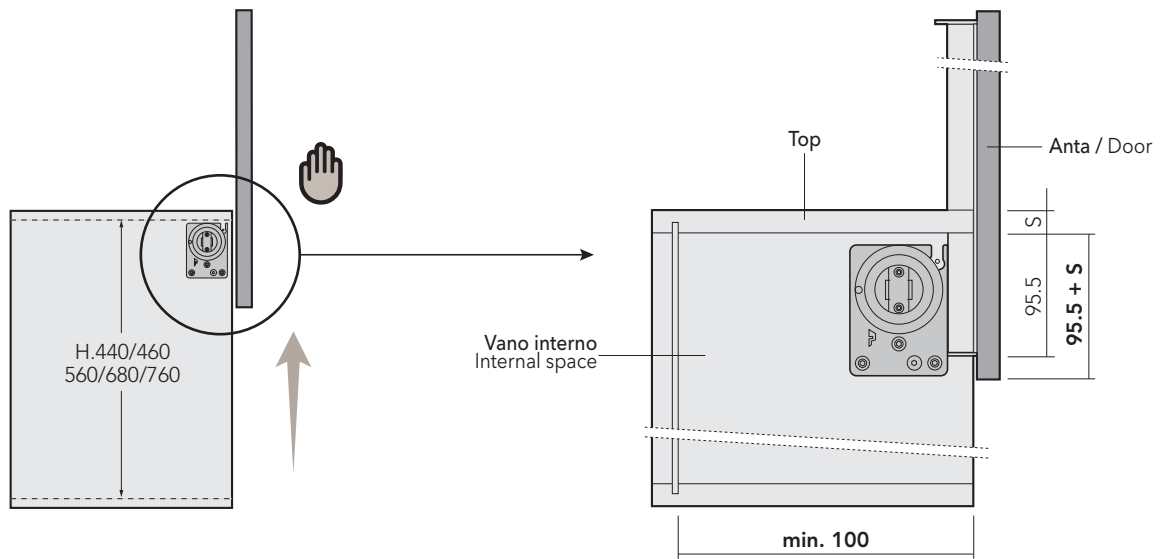



CARATTERISTICHE / CHARACTERISTICS

Tutte le dimensioni si riferiscono alla misura del VANO INTERNO
All dimensions refer to the size of the INSIDE SPACE 

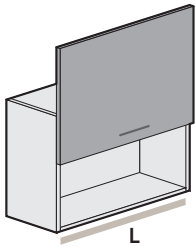

Interno vano - Lunghezza a piacere
Inside space - Width to pleasure

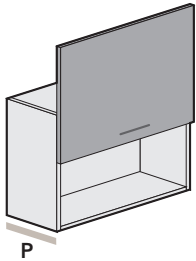

Prof. Interno vano - min. 100 mm
Internal space depth - min. 100 mm

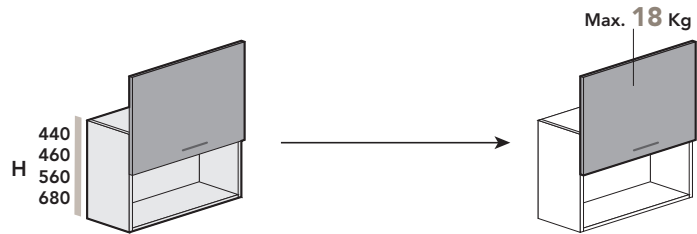

Altezza / Height
H. 440 mm - 460 mm
H. 560 mm - 680 mm

Peso anta / Door weight
max. 18 Kg

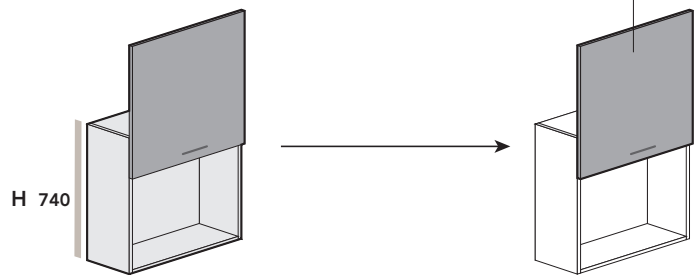

Altezza / Height
H. 740 mm

Peso anta / Door weight
max. 13 Kg





HONGKONG HARDWARE SUPPLIER LTD

香港裝飾材料有限公司

APERTURA ELETTRICA ELECTRICAL OPENING

In caso di blackout
l'apertura diventa manuale
In case of blackout
the opening becomes manual



MECCANISMO VERT-MOVE / VERT-MOVE MECHANISM

BARRA DI COLLEGAMENTO 15x15 / CONNECTION BAR 15x15

KIT MOTORIZZAZIONE (comprensivo di radiocomando) / ENGINE TYPE KIT (with remote control)

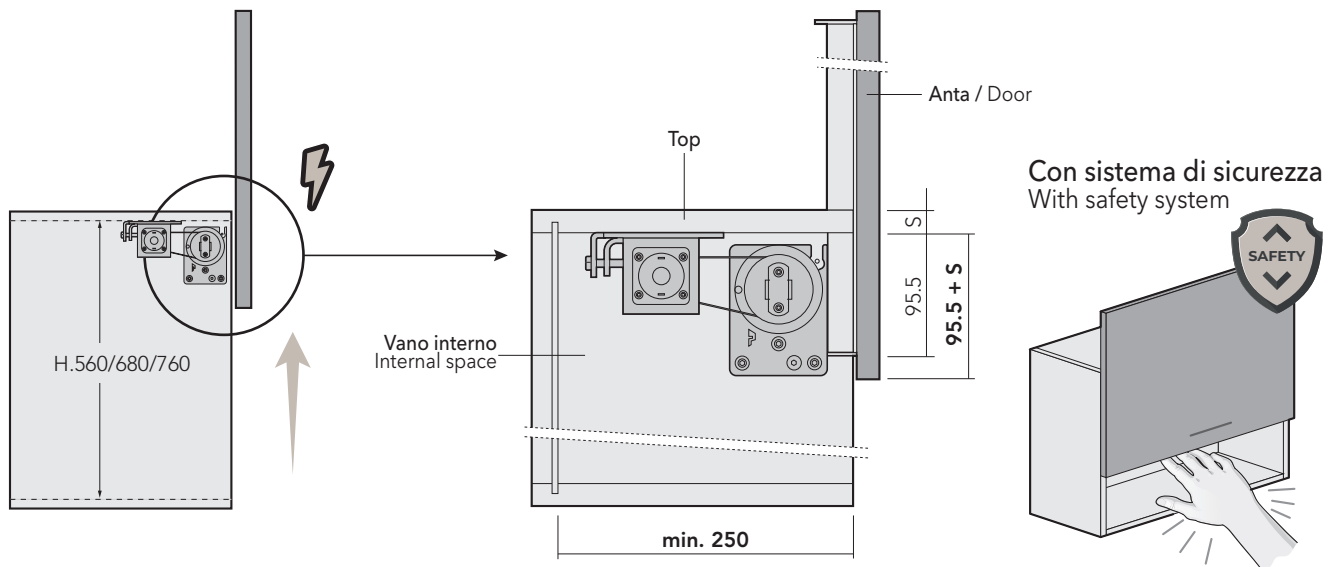



Centro ricerche sviluppo laboratorio prove settore legno/arredo
TESTATO PER 50.000 CICLI
TESTED FOR 50.000 CYCLES



CARATTERISTICHE / CHARACTERISTICS

Tutte le dimensioni si riferiscono alla misura del VANO INTERNO
All dimensions refer to the size of the INSIDE SPACE

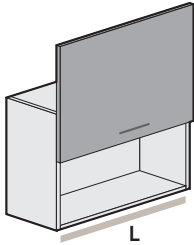

Interno vano - Lunghezza a piacere
Inside space - Width to pleasure

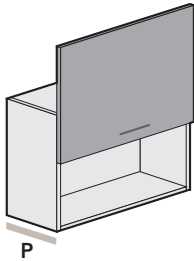

Prof. Interno vano - min. 250 mm
Internal space depth - min. 250 mm

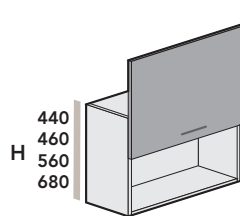

Altezza / Height
H. 440 mm - 460 mm
H. 560 mm - 680 mm

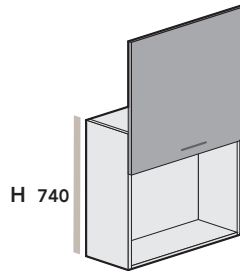

Altezza / Height
H. 740 mm

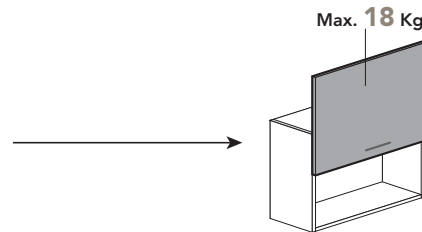

Peso anta / Door weight
max. 18 Kg

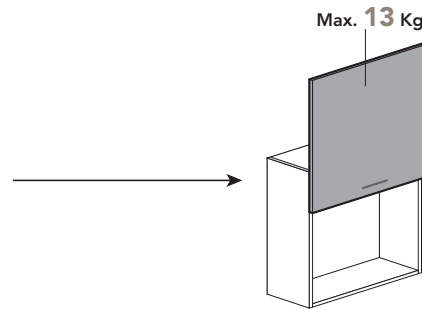

Peso anta / Door weight
max. 13 Kg





OPTIONAL - APERTURA ELETTRICA

OPTIONAL - ELECTRICAL OPENING



INTERFACCIA SONOFF PER DOMOTICA / SONOFF INTERFACE FOR HOME AUTOMATION



- Remote ON/OFF
- Smart Timer
- Feedback Status
- Self-locking mode
- Interlock mode
- Inching mode





COMPONENTI

COMPONENTS

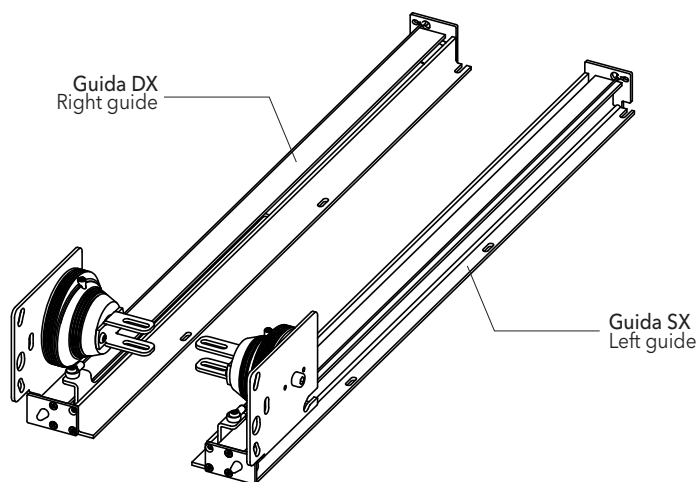

BARRA DI COLLEGAMENTO 15x15 / CONNECTION BAR 15x15

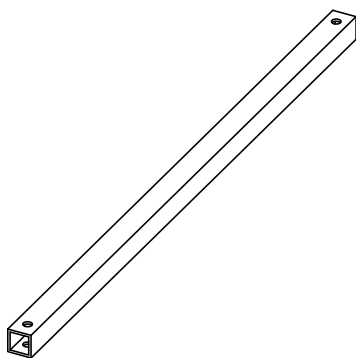

KIT MOTORIZZAZIONE (comprensivo di radiocomando)

ENGINE TYPE KIT (with remote control)

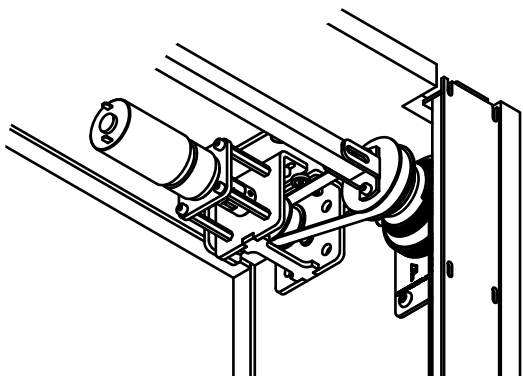

Codice / Code	Descrizione / Description	Peso Anta / Door Weight (Kg)
304506801		4,7
304506802		5,4
304506803		6,1
304506804		6,8
304506805		7,4
304506806		8,1
304506807		8,8
304506808		9,5
304506809		10,1
304506810		10,8
304506811		11,5
304506812		12,2
304506813		12,8
304506814		13,5
304506815		14,2
304506816		14,9
304506817		15,5
304506818		16,2
304506819		16,9
304506820		17,6

Codice / Code	Descrizione / Description	L (mm) = (L1 - 150mm)	L1 (mm)	S (mm)
619045014	Barra Coll. 15x15	450	600	16 ÷ 25
619075014	Barra Coll. 15x15	750	900	16 ÷ 25
619105014	Barra Coll. 15x15	1050	1200	16 ÷ 25
619135014	Barra Coll. 15x15	1350	1500	16 ÷ 25
619165014	Barra Coll. 15x15	1650	1800	16 ÷ 25

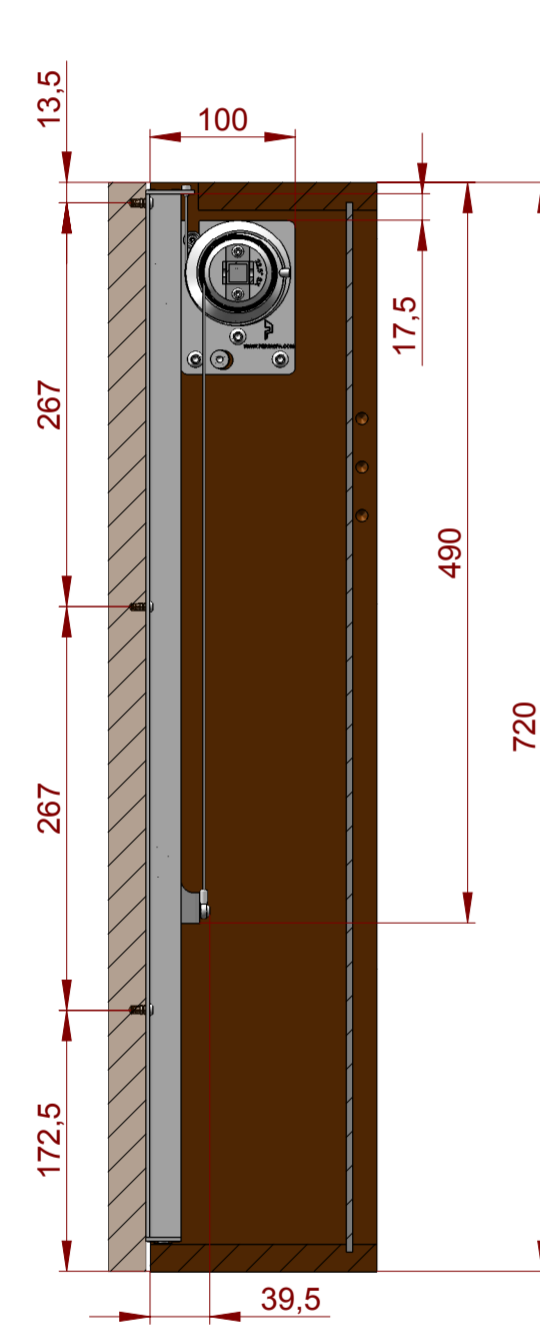
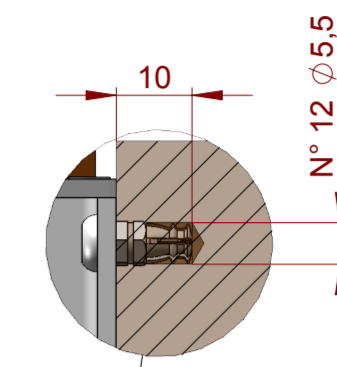

SEZIONE B-B

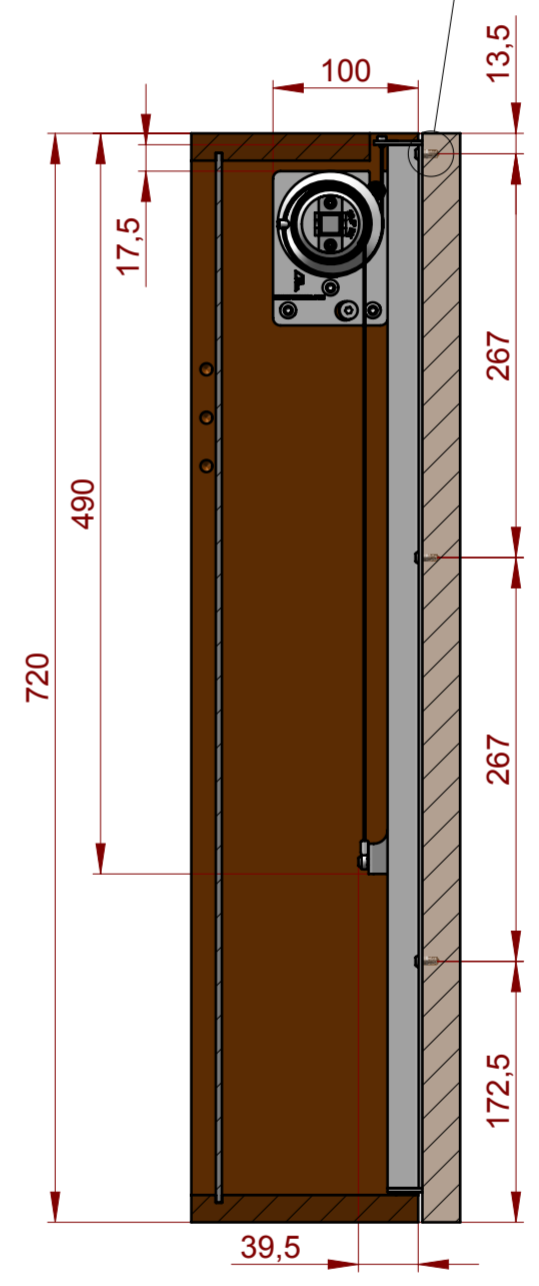
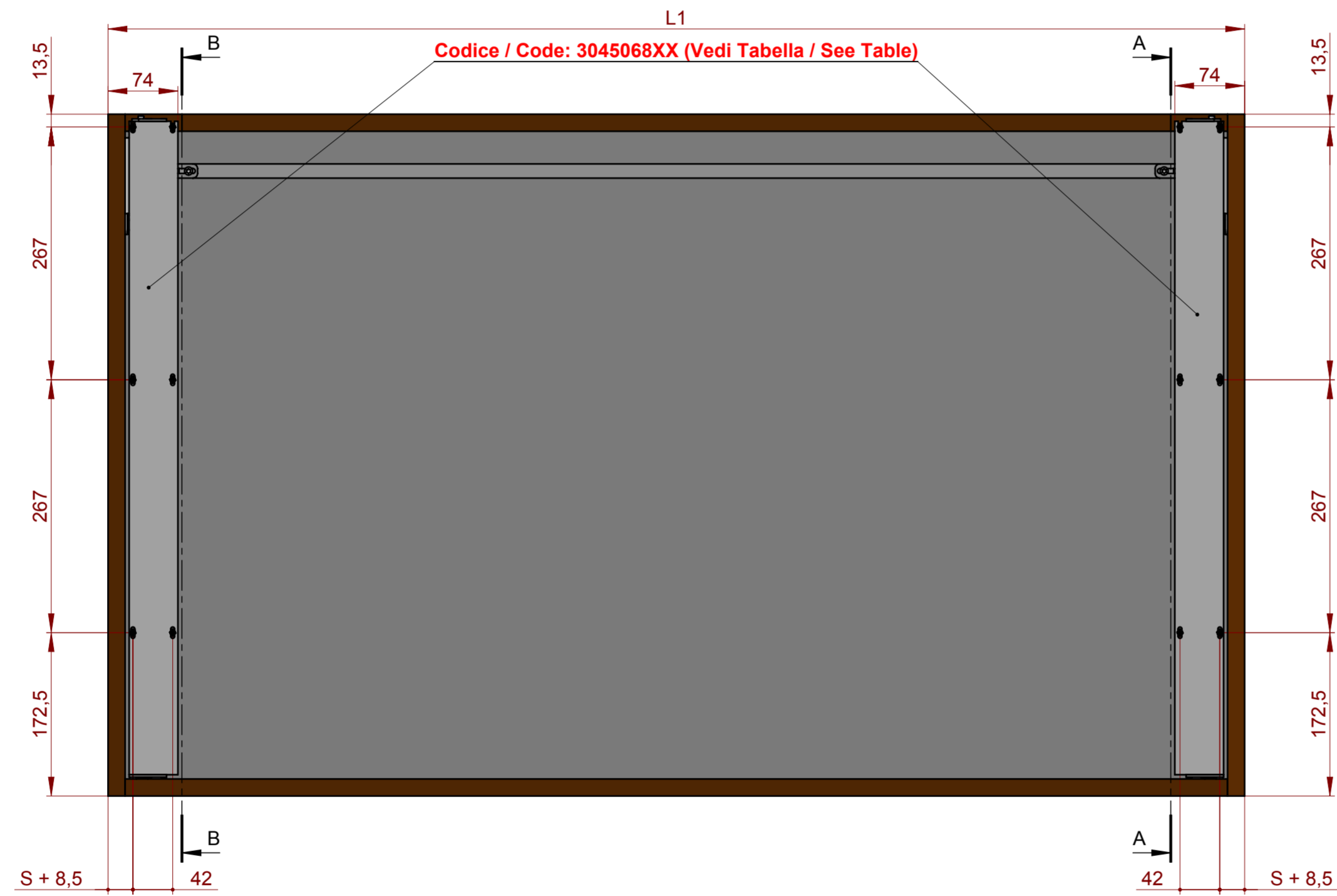

SEZIONE A-A

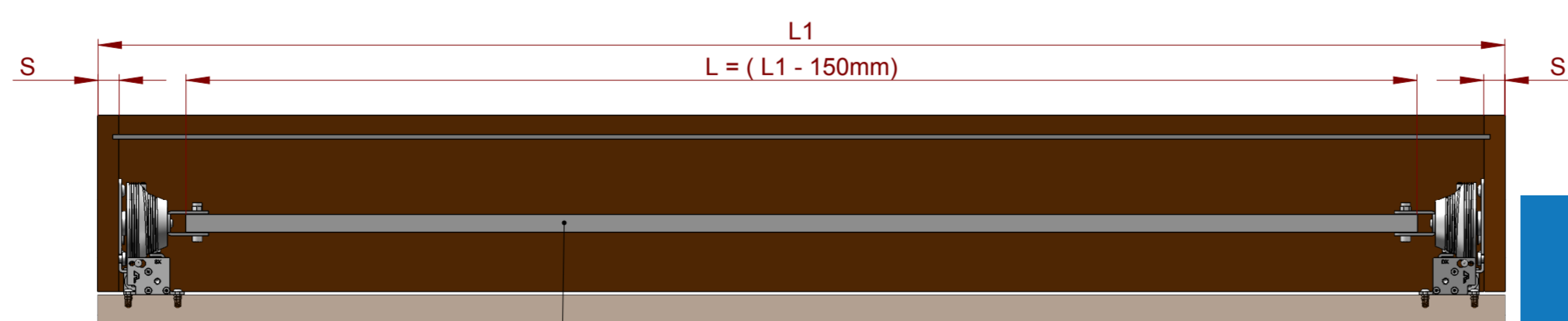

Codice / Code : 619XXX14 (Vedi Tabella / See Table)

HONGKONG HARDWARE SUPPLIER LTD
香港裝飾材料有限公司

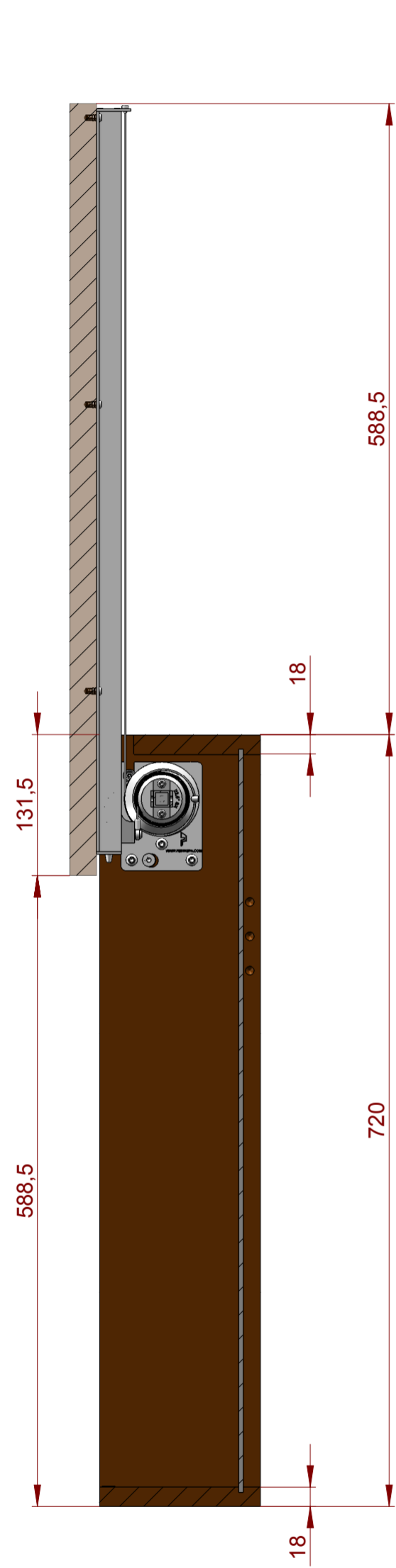

SEZIONE D-D

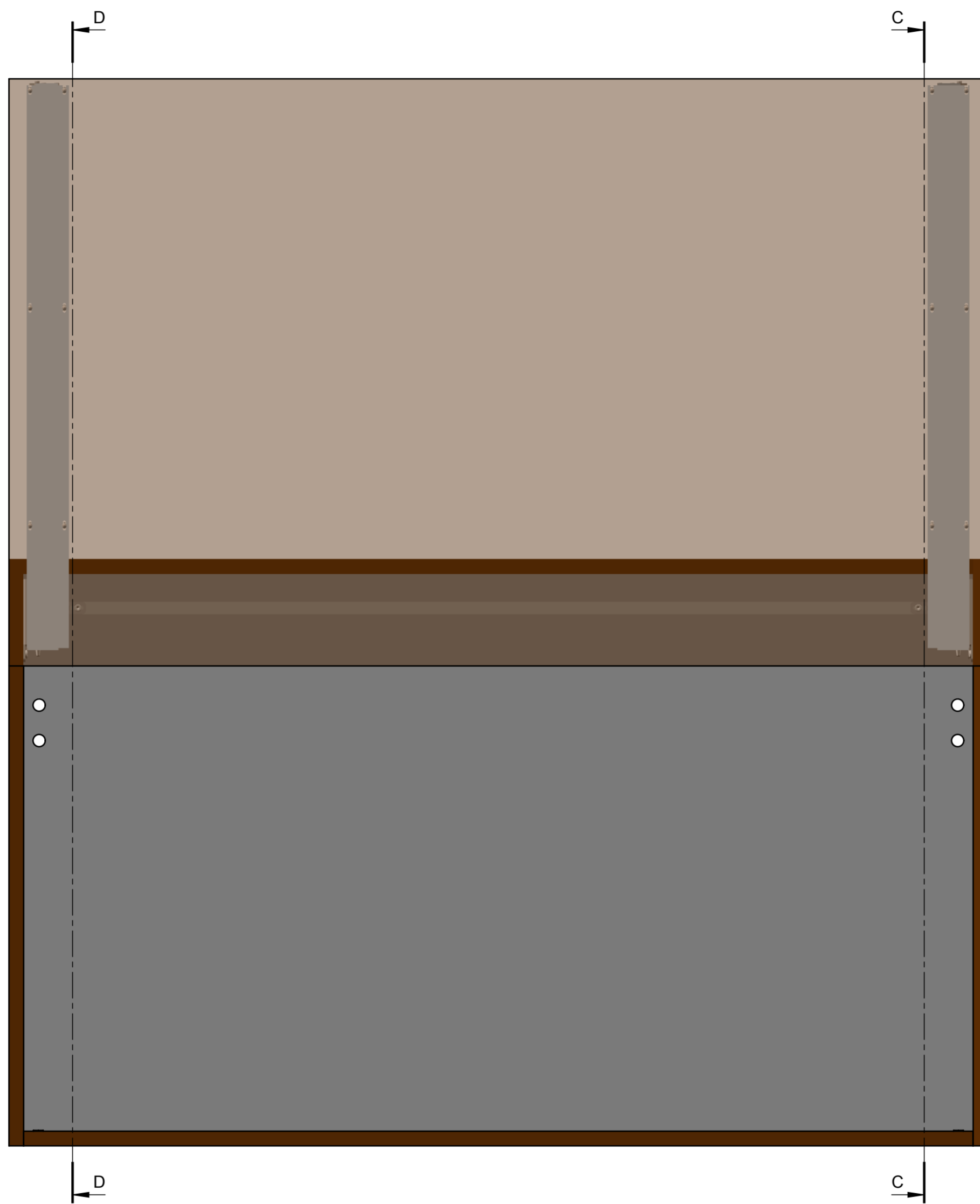

SEZIONE C-C



HONGKONG HARDWARE SUPPLIER LTD

香港裝飾材料有限公司