

SLIDING DOORS

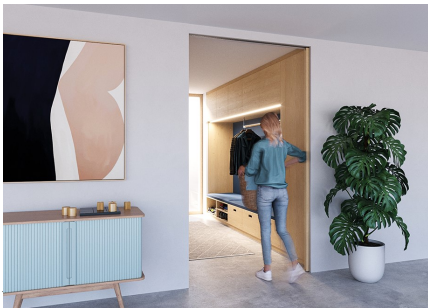

Hawa Porta 100 HMT - the clever pocket door solution for wooden sliding doors
Hawa Porta 100HMT—牆套內安裝木質移門的巧妙解決方案



Efficient movement support with Push-to-Open with self-closing mechanism for the Hawa Porta 100 HMT
Hawa Porta 100HMT 的自閉裝置能與按彈裝置同時使用，提供高效能移動

- * The drill hole for the safety lock screw must be accessible
- * 安全鎖螺絲的鑽孔必須是可觸及的

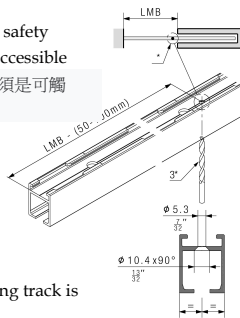

Dismounting the running track is simple and easy
移除路軌的方法簡單、容易

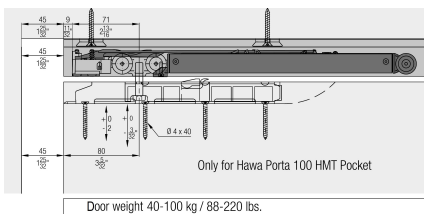
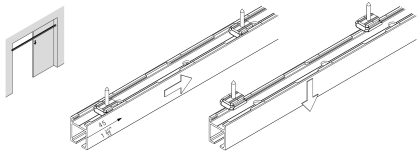

Push-to-open with self-closing mechanism:
按彈開啟連自閉裝置

- height adjustment +/- 3 mm
門扇安裝高度可調 +/- 3 mm

HKS-3027

Hawa Porta 100 HMT Pocket sliding system for single top-running wooden door for installation in wall pocket, with recessed mounted rollers, surface mounted aluminium anodized running track, Push-to-open with self-closing and soft-closing mechanism

Hawa Porta 100 HMT 牆套內安裝版單扇木質移門五金連嵌入安裝用滾輪、鋁質頂吊路軌、按彈開啟連自閉裝置和阻尼裝置

- Track length 路軌長度 : 2000 mm
- Max. door weight 門承重 : 100 kg per door (每扇門計)
- Max. door width 門最大寬度 : 1600 mm
- Max. door height 門最大高度 : 2700 mm
- Door thickness 門厚度 : 30-40 mm

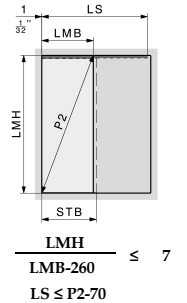
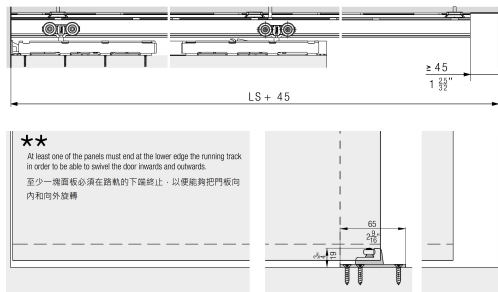
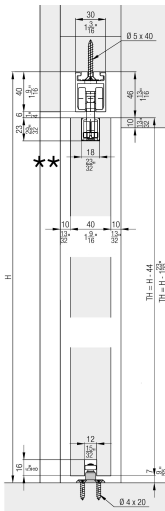
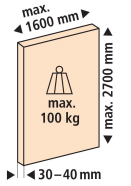

LMB = Internal width 內寬度 LS = Running track length 路軌長度 P2 = Diagonal clearance 對角線間隙
LMH = Internal height 內高度 STB = Sliding door width 推拉門寬度

**! The running track length must be 70 mm shorter than the diagonal clearance P2
! 路軌長度必須比對角線間隙 P2 短 70 mm**

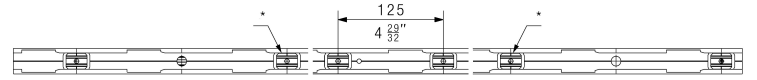

Surface-mounted running track installation
表面安裝路軌

- * Fit adapters to first and last drill hole and then every alternate drill hole, and right and left of the drill hole for the safety lock screw
- * 將扣碼分別安裝在以下的位置：第一個和最後一個鑽孔、每個間隔鑽孔及安全鎖定螺絲的鑽孔的右側和左側

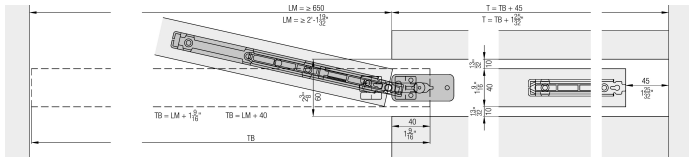

LM = Internal dimension 內尺寸
TB = Door width 門寬度
T = Pocket depth 牆套內深度

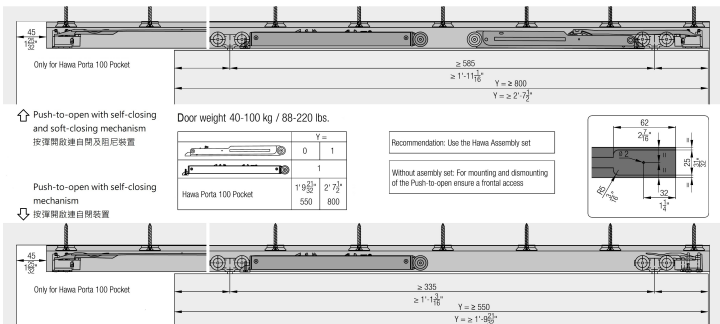

Push-to-open soft-closing mechanism
按彈開啟自閉裝置



Accessories included in a set:
每套包含以下配件：

2x	2x	1x	1x	1x	1x	2x	1x	1x	1x
1x	1x	1x	1x	8x	1x	4x	2m	9x	10x