

DYNAPRO SLIDE SYSTEM FOR WOODEN DRAWERS
DYNAPRO TIPMATIC SOFT-CLOSE

Made in Austria
奧地利製造



HKS-7002T

Dynapro Tipmatic (Touch to Open) Soft-close set
Dynapro 一按即開阻尼關閉配件套裝

Each set comprising 每套包括配件:

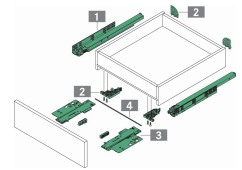

1 pair	Dynapro Tipmatic Soft-close ejector unit, left & right Dynapro 一按即開阻尼關閉彈出部件, 左及右	
1 pair	Dynapro Tipmatic Soft-close activator, left & right Dynapro 一按即開阻尼關閉觸動器, 左及右	
1 pc	Synchronization rod for Dynapro Tipmatic Soft-close, 952 mm (L) (for cutting to length) 同步橫杆, 952 mm 長(可裁切)	

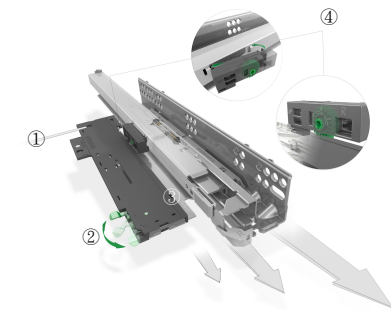

The above Tipmatic Soft-close parts are used for Dynapro Soft-close full extension concealed slide with front locking device and adjustment adapter set

以上一按即開阻尼關閉組件需要配合 Dynapro 阻尼全趟隱藏式抽屜滑軌連扣碼及調節碼一併使用

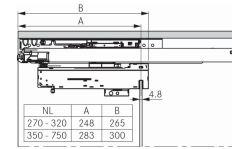

Position of the synchronization rod
同步橫杆位置

The new Tipmatic Soft-close opening system combines the advantages of mechanical system with the comfort of the proven Soft-close damper. 最新的一按即開阻尼系統集結了機械式免拉手開啟和輕柔阻尼閉合的好處

- ① Large activation area thanks to the synchronization rod
大面積碰觸, 使用更加舒適
- ② 3-level adjustment of the opening force.
One ejector unit for all nominal lengths and weight classes
無需工具進行開啟力度3種調節。同一組件適用於所有尺寸和重量的抽屜
- ③ Simple fitting of the ejector unit and the activator to the standard Dynapro soft-close slide
安裝簡單容易
- ④ Integrated, tool-free depth adjustment (+3/-1 mm). Low minimum front gap of 2.5 mm
免工具深度調節 (+3/-1 mm), 面板間隙只需 2.5 mm

Model No. 型號	Nominal Length 標示長度	Drawer Length 抽屜長度	Min. Installation Depth 最少安裝深度	Loading 載重
HKS-7002/250*	250 mm	240 mm	253 mm	40 kg
HKS-7002T/A	300 mm	290 mm	303 mm	40 kg
HKS-7002T/B	350 mm	340 mm	353 mm	40 kg
HKS-7002T/C	400 mm	390 mm	403 mm	40 kg
HKS-7002T/D	450 mm	440 mm	453 mm	40 kg
HKS-7002T/E	500 mm	490 mm	503 mm	40 kg
HKS-7002T/F	550 mm	540 mm	553 mm	40 kg
HKS-7002TB/G	600 mm	590 mm	603 mm	70 kg
HKS-7002TB/H	650 mm	640 mm	653 mm	70 kg

* 250 mm nominal length cannot combine Tipmatic function with Soft-close damping

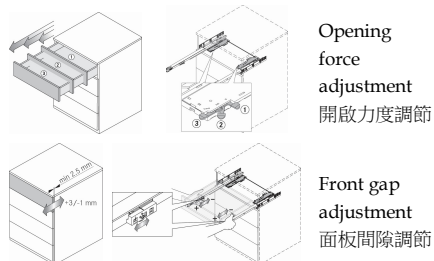

Opening force adjustment
開啟力度調節

Front gap adjustment
面板間隙調節

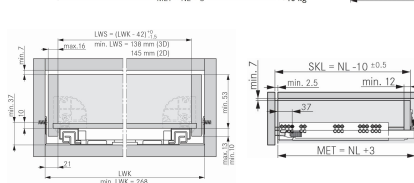
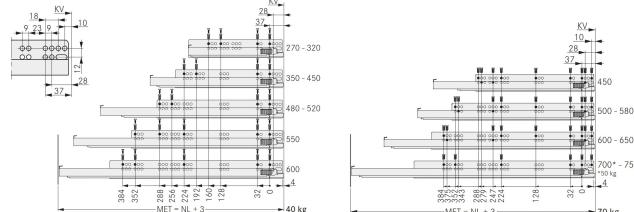

Installation dimension
安裝尺寸

Drawer
抽屜

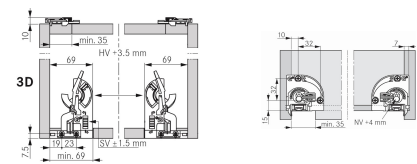

Locking device & adj. adapter fixing position
抽屜扣碼及調節碼安裝位置

Fixing positions for full extension drawer
全拉出抽屜趟路鑽孔尺寸、跟櫃體前端尺寸

HV	Height adjustment	高度調節
KV	Front edge of cabinet	櫃體前端
LWK	Inside cabinet width	櫃體內寬度

LWS	Internal drawer width	抽屜內寬度
MET	Minimum installation depth	最少安裝深度
NL	Nominal length	標示長度

NV	Tilt angle adjustment	傾斜調節
SV	Side adjustment	側邊調節